

<b>Specification</b>	<b>AXE25</b>	Rev.: 1	Date: 2014-04-04
----------------------	--------------	---------	------------------

**Oscillator type: Crystal Oscillator (SPXO) in double-sealed DIL14 package**

Parameter	min.	typ.	max.	Unit	Condition
<b>Frequency range</b>	1		150	MHz	
<b>Frequency stability</b>					
Overall stability (Note 2)	±10 to ±100 See table 1			ppm	Option 2
vs. operating temperature range	See table 2				Option 3
Long term (aging) per year			±2	ppm	@ 40°C
<b>RF output</b>					
Signal waveform	Sine Wave				
Load	50			Ω	± 10%
Output level	+3			dBm	
Harmonics			-30	dBc	
Start-up time			10	ms	
<b>Supply voltage V<sub>s</sub></b>	3.15	3.3	3.45	V	Option 1 = "33"
	4.75	5.0	5.25	V	Option 1 = "50"
<b>Current consumption (steady state)</b> (Note 3)			45	mA	Option 1 = "33"
			25	mA	Option 1 = "50"
<b>Enclosure (see drawing) (LxWxH)</b>	20.7x13.1x7.5 max.			mm	IEC 60679-3 CO 02
<b>Weight</b>			5	g	
<b>Packing</b>	Palette or Tube				IEC 60286-3

**Notes:**

1. Terminology and test conditions are according to IEC60679-1 and MIL-PRF-55310, unless otherwise stated
2. Other stabilities on request
3. Depending on frequency and supply voltage
4. All combinations of options might not be available. Please consult factory

**Absolute Maximum Ratings**

Parameter	min.	max.	Unit	Condition
Supply Voltage V <sub>s</sub>	-0.5	V <sub>s</sub> + 10%	V	V <sub>s</sub> to GND
Storage Temperature	-55	+125	°C	

**Overall stability and temperature range**

Option 2	Stability [ppm]
10	±10
15	±15
25	±25
50	±50
100	±100

Table 1

Lower Temperature		Upper Temperature	
Option 3	T [°C]	Option 3	T [°C]
0	0	A	+50
1	-10	B	+60
2	-20	C	+70
3	-30	D	+75
4	-40	E	+80
5	-55	F	+85
		G	+105
		H	+125

Table 2

## Ordering Code

Model	Option 1 [Supply Voltage]	Option 2 [Stability]	Option 3 [Temperature range]	Revision	Frequency [MHz]
AXE25	33 or 50	Table 1	Table 2	Rev.1	10.000

Example: AXE25-50-25-2C\_Rev.1 – 10.000 MHz

## Enclosure drawing

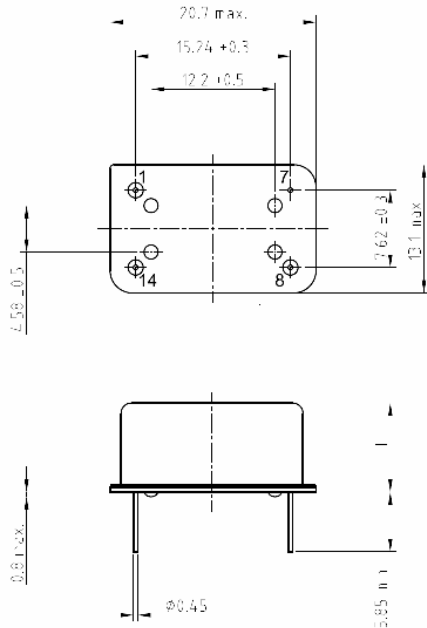

## Pin connections

Pin #	Symbol	Function
1	N.C.	No Connection
7	GND	Ground
8	RF OUT	RF Output
14	Vs	Supply Voltage

## Handling and Testing

Parameter	Procedure		Source
Handling and Testing	Application Note AXAN-011		www.axtal.com
Processing	Application Note AXAN-012		www.axtal.com
Parameter	Procedure		Condition
Electrostatic discharge (ESD)			
THD devices	IEC60749-26	HBM	2000 V
SMD devices	IEC60749-27	MM	200 V
Washable	<input checked="" type="checkbox"/> Yes <input type="checkbox"/> No		
RoHS compliant	<input checked="" type="checkbox"/> Yes <input type="checkbox"/> No		

### Environmental conditions

Test	IEC 60068 Part ...	IEC 60679-1 Clause	MIL-STD- 202G Method	MIL-STD- 810F Method	MIL-PRF- 55310D Clause	Test conditions (IEC)
Sealing tests (if applicable)	2-17	5.6.2	112E		3.6.1.2	Gross leak: Test Qc, Fine leak: Test Qk
Solderability Resistance to soldering heat	2-20 2-58	5.6.3	208H 210F		3.6.52 3.6.48	Test Ta Method 1 Test Td <sub>1</sub> Method 2 Test Td <sub>2</sub> Method 2
Shock*	2-27	5.6.8	213B	516.4	3.6.40	Test Ea, 3 x per axes 100g, 6 ms half-sine pulse
Vibration, sinusoidal*	2-6	5.6.7.1	201A 204D	516.4-4	3.6.38.1 3.6.38.2	Test Fc, 30 min per axes, 10 Hz - 55 Hz 0,75mm; 55 Hz - 2 kHz, 10g
Vibration, random*	2-64	5.6.7.3	214A	514.5	3.6.38.3 3.6.38.4	Test Fdb
Endurance tests - ageing - extended aging		5.7.1 5.7.2	108A		4.8.35	30 days @ 85°C, OCXO @25°C 1000h, 2000h, 8000h @85°C

Other environmental conditions on request

Data sheet is for information purposes only and may be subject to modifications or may be discontinued without notice.

### Revision History

Rev.	Drawing	Date [dd.mm.yyyy]	Remarks	Author	Checked
1	D0	04.04.2014	First issue	HH	HH