

Specification	AXQCM508B	Rev.: 1	Date: 2020-10-04
---------------	-----------	---------	------------------

Quartz Crystal Microbalance Element (Monitor Crystal)



Parameter	min.	typ.	max.	Unit	Condition
Nominal frequency		5.000		MHz	
Adjustment frequency		4.960		MHz	
Crystal cut		AT			35°15'±1'
Overtone		1			
Frequency tolerance	-7		+7	kHz	
Frequency stability					
Over operating temperature range	-50		+50	ppm	
Resonance resistance R _r			15	Ω	
Motional capacitance C ₁				fF	
Shunt capacitance C ₀			20	pF	
Drive level		100		μW	
Operating temperature range	+60	+70	+80	°C	
Storage temperature range	-40		+105	°C	
QCM diameter	13.97 +0/-0.03			mm	Plano-convex
Convex radius	210			mm	
Blank surface quality	Fine lapped				R _a = 0.8 ~ 1.6 μm
Electrode diameter Side A	13.3 ± 0.1			mm	Fully plated
Electrode material Side A	Cr-Ag				
Electrode diameter Side B	6.0 ± 0.1			mm	See drawing
Electrode material Side B	Cr-Ag				

Side A (Plane)

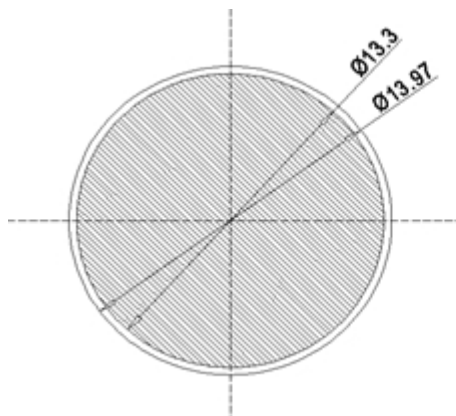

Side B (Convex)

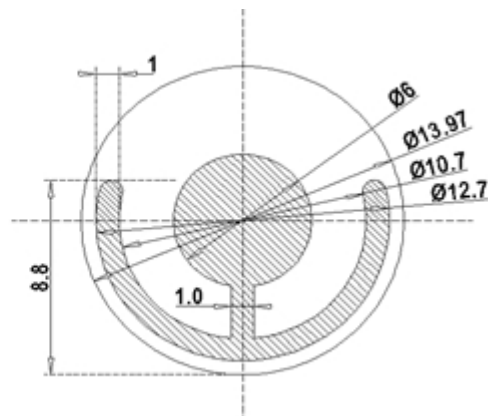

Ordering Code:

Model (Specification)	Revision	Frequency [MHz]
AXQCM508B	1	4.960

Revision History

Rev.	Drawing	Date [dd.mm.yyyy]	Remarks	Author	Checked
1	D0	04.10.2020	First issue AXQCM508B	BN	BN