

Specification	AXQCS503M	Rev.: 1	Date: 2021-02-12
---------------	-----------	---------	------------------

## Quartz Crystal Sensor Element



Parameter	min.	typ.	max.	Unit	Condition
Nominal frequency		5.000		MHz	
Adjustment frequency		5.000		MHz	
Crystal cut		AT			35°15'±2'
Overtone		1			
Frequency tolerance	-7		+7	kHz	
Frequency stability					
Over operating temperature range	-50		+50	ppm	
Resonance resistance R <sub>r</sub>			20	Ω	
Motional capacitance C <sub>1</sub>				fF	
Shunt capacitance C <sub>0</sub>			20	pF	
Drive level		100		μW	
Operating temperature range	+60	+70	+80	°C	
Storage temperature range	-40		+105	°C	
QCM diameter		25.4 +0/-0.03		mm	Plano-plano with bevel
Blank surface quality		Polished			R <sub>a</sub> = 0.012 ~ 0.05 μm
Electrode diameter Side A		12.8		mm	Key hole, wrapped around
Electrode material Side A		Ti-Au-Mo			
Electrode diameter Side B		6.4		mm	anchor
Electrode material Side B		Ti-Au			

Side A (Plane)

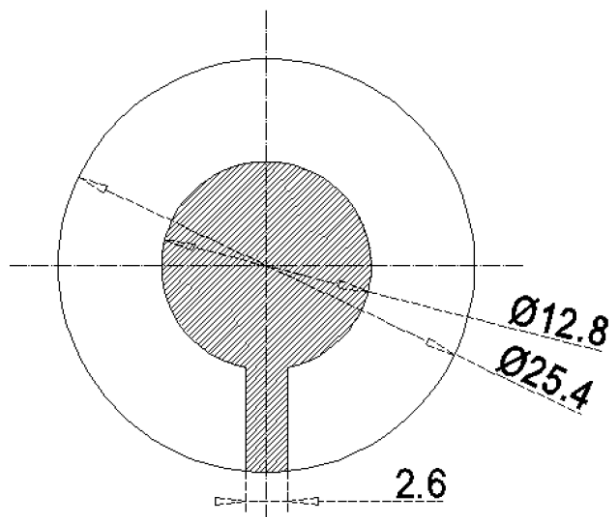

Side B (Plane)

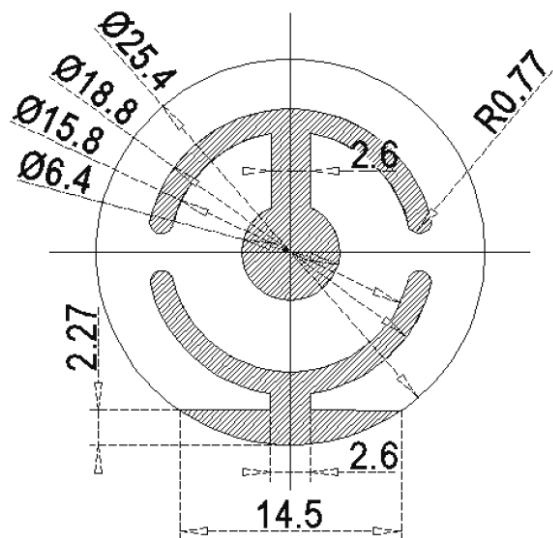

### Ordering Code:

Model (Specification)	Revision	Frequency [MHz]
AXQCS503M	1	5.000

**Revision History**

Rev.	Drawing	Date [dd.mm.yyyy]	Remarks	Author	Checked
1	D0	12.02.2021	First issue AXQCS503M	BN	BN